

STEEL & ALUMINUM WHEEL RISERS MODELS SWR & AWR

USED TO RAISE TRUCKS TO DOCK HEIGHT

WHEEL RISERS ARE CUSTOM MADE TO EACH UNIQUE APPLICATION.

PRICING WILL BE PROVIDED BASED ON SPECIFICATIONS UPON COMPLETION OF WORKSHEET

STEEL WHEEL RISER

SWR82454



Steel Wheel Risers (SWR)

- Have 4 tabs with 9/16" holes for anchoring
- Fork pockets in place of tabs are available at no additional cost

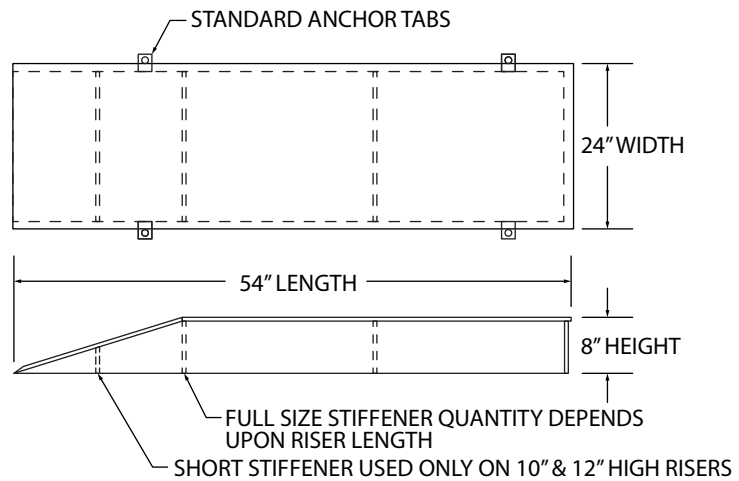

ALUMINUM WHEEL RISER

AWR82454

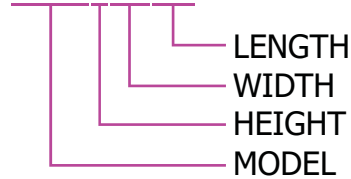

Aluminum Wheel Risers (AWR)

- Have cur outs for lifting by hand
- 4 tabs with 9/16" holes for anchoring are available at no additional cost

